

HarmonicDrive®

CSG Series Fully Enclosed Close Coupled Unit

A fully enclosed close coupled unit has been added to the HarmonicDrive® CSG series.

A fully enclosed close coupled unit has been developed and added to the HarmonicDrive® CSG series which is the highest specification model in the all HarmonicDrive® series, in order to fulfill the lineup. Retaining the flat shape of the HarmonicDrive® as its advantage to adopt the fully enclosed structure makes it to be easily designed and handled.

It is your suitable product for the mechanical parts for work handling or magazine drives in machine tools or general industrial automation machine.



Feature

- Customer can reduce design lead time compared with conventional products.
- Less numbers of parts installed to motor makes it easier to design compact.
- Adaption of the input spline makes it easier to install a motor.

■ Ordering Code

CSG - 25 - 100 - 2UK - A01 - SP 2

Model name: CSG series	Size: 25 to 65 (excluding 50)	Ratio: 1/50 to 1/160	Model: 2UK = sealing unit	Spline outer diameter size: A: approx. 29mm, B: approx. 44 mm, C: approx. 54 mm	Form symbol (design order serial number): 01 to 05	Specification 2: SP = Special specification None = Standard product
----------------------------------	---	--------------------------------	-------------------------------------	---	--	---

■ Structural Drawing

Figure 2-1

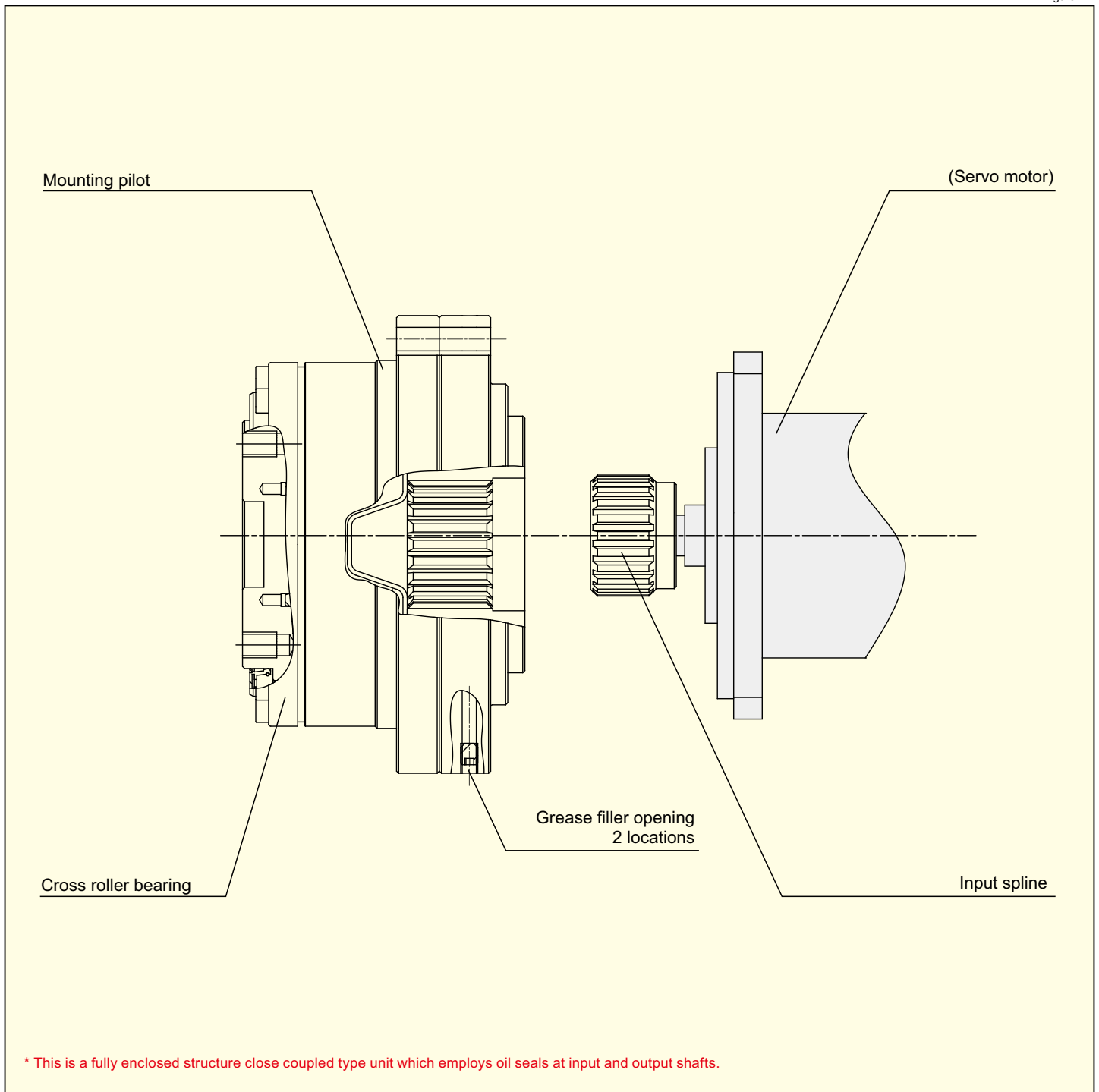

Rating Table

Table 3-1

Size	Ratio	Rated Torque at Input Speed 2000 r/min		Limit for Repeated Peak Torque		Limit for Average Torque		Limit for Momentary Peak Torque		Maximum Input Speed r/min	Limit for Average Input Speed r/min	Moment of inertia (including input spline)	
		Nm	kgfm	Nm	kgfm	Nm	kgfm	Nm	kgfm	Grease lubricant	Grease lubricant	I ×10 ⁻⁴ kgm ²	J ×10 ⁻⁴ kgms ²
25	50	51	5.2	127	13	72	7.3	242	25	5600	3500	0.65	0.66
	80	82	8.4	178	18	113	12	332	34				
	100	87	8.9	204	21	140	14	369	38				
	120	87	8.9	217	22	140	14	382	39				
	160	87	8.9	229	23	140	14	382	39				
32	50	99	10	281	29	140	14	497	51	4800	3500	1.4	1.4
	80	153	16	395	40	217	22	738	75				
	100	178	18	433	44	281	29	841	86				
	120	178	18	459	47	281	29	842	86				
	160	178	18	484	49	281	29	842	86				
40	50	178	18	523	53	255	26	892	91	4000	3000	3.55	3.6
	80	268	27	675	69	369	38	1270	130				
	100	345	35	738	75	484	49	1400	143				
	120	382	39	802	82	586	60	1488	152				
	160	382	39	841	86	586	60	1488	152				
45	50	229	23	650	66	345	35	1235	126	3800	3000	8/78	8.9
	80	407	41	918	94	507	52	1651	168				
	100	459	47	982	100	650	66	2041	208				
	120	523	53	1070	109	806	82	2288	233				
	160	523	53	1147	117	819	84	2483	253				
58	80	714	73	1924	196	1001	102	3185	325	3000	2200	19.9	20.3
	100	905	92	2067	211	1378	141	4134	422				
	120	969	99	2236	228	1547	158	4329	441				
	160	969	99	2392	244	1573	160	4459	455				
65	80	969	99	2743	280	1352	138	4836	493	2800	1900	43.8	44.7
	100	1236	126	2990	305	1976	202	6175	630				
	120	1236	126	3263	333	2041	208	6175	630				
	160	1236	126	3419	349	2041	208	6175	630				

(Note) 1. Moment of inertia = $1/4 \cdot GD^2$
 2. For details about terms, refer to "engineering data in HarmonicDrive® general catalog."

■ No Load Running Torque

No load running torque is the input torque (high-speed shaft side) that is required to rotate a HarmonicDrive® with no load applied to the output.

Measurement condition

Table 4-1

Ratio 100			
Lubrication condition	Grease lubricant	Name	Harmonic Grease®4B No.2
		Application qty.	Appropriate application quantity
The torque value is measured after two or more hours run-in at 2000r/min input.			

Temperature range of the operating environment

Table 4-3

Grease	Harmonic Grease® 4BNo2 -10 °C to +70 °C
--------	---

Compensation value for each ratio

The no load running torque for HarmonicDrive® varies depending on the gear ratio.

The following graph shows the value for ratio 100. Other gear ratios must be calculated by adding the compensation value indicated in Table 4-2.

No load running torque compensation value

Table 4-2

Size \ Ratio	50	80	120	160
25	3.8	0.7	-0.5	-1.2
32	7.1	1.3	-0.9	-2.2
40	12	2.1	-1.5	-3.5
45	16	2.9	-2.1	-4.9
58	—	5.3	-3.8	-8.9
65	—	7.2	-5.1	-12

Unit: cNm

No load running torque at ratio 100

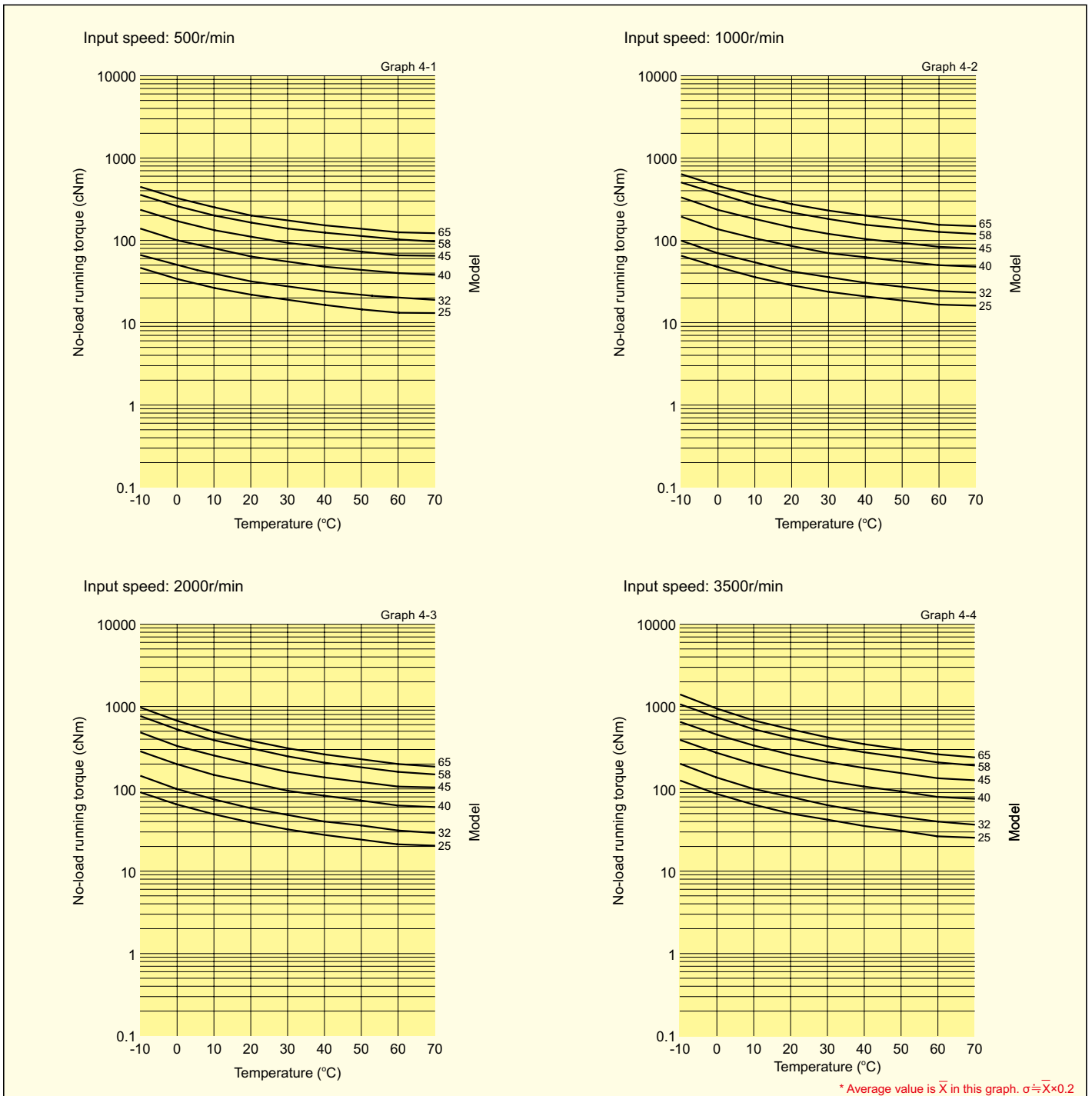

Efficiency Characteristics

The efficiency varies depending on the following conditions.

- Ratio
- Input speed
- Load torque
- Temperature
- lubrication condition (Lubrication type and its quantity)

* Consult us in the case of oil lubricant.

Efficiency compensation coefficient and efficiency compensation amount

Efficiency compensation calculation formula

Efficiency compensation coefficient by load torque and efficiency compensation amount by size must be calculated by using the equation of formula 5-1.

Calculation formula

Equation 5-1

$$\text{Efficiency } \eta = K_e \times (\eta_R + \eta_e)$$

Efficiency compensation coefficient by load torque

The value of efficiency drops when load torque is smaller than rated torque.

Calculate the value of efficiency by calculating compensation coefficient K_e with the reference to the efficiency compensation calculation formula.

Efficiency compensation coefficient

Graph 5-1

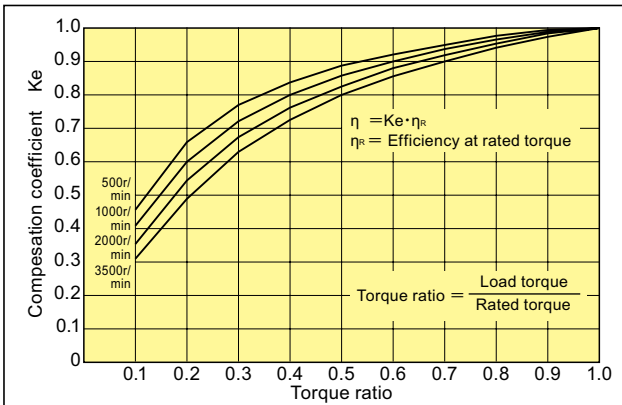

*When load torque is larger than rated torque, efficiency compensation coefficient $K_e = 1$.

Measurement condition

Table 5-1

Installation	Recommended tolerance		
Load torque	Rated torque indicated in the rated table		
Lubrication condition	Grease lubricant	Title	Harmonic Grease®4B No.2
		Application qty.	Appropriate application quantity

Table for the symbols in calculation formula

Table 5-2

η	Efficiency	—
K_e	Efficiency compensation coefficient	Graph 5-1
η_R	Efficiency at rated torque	Graphs 5-2 to 5-4
η_e	Efficiency compensation amount	Table 5-3

Efficiency compensation amount by size

CSG-2UK employs support bearing and oil seal on the input side. The influence from those parts vary depending on the size. Compensation amount η_e at rated torque by size must be calculated from Table 5-3.

Table for the efficiency compensation amount by size

Table 5-3

Size \ Ratio	50	80	100	120	160
25	-2.0	-1.1	-4.7	-6.8	-5.8
32	1.4	2.6	0.5	-1.1	0.8
40	0.0	0.0	0.0	0.0	0.0
45	-3.7	-1.7	-4.0	-3.8	-2.5
58	—	0.6	0.2	-0.3	1.7
65	—	1.7	1.4	-0.1	1.9

Unit: %

Efficiency at Rated Torque

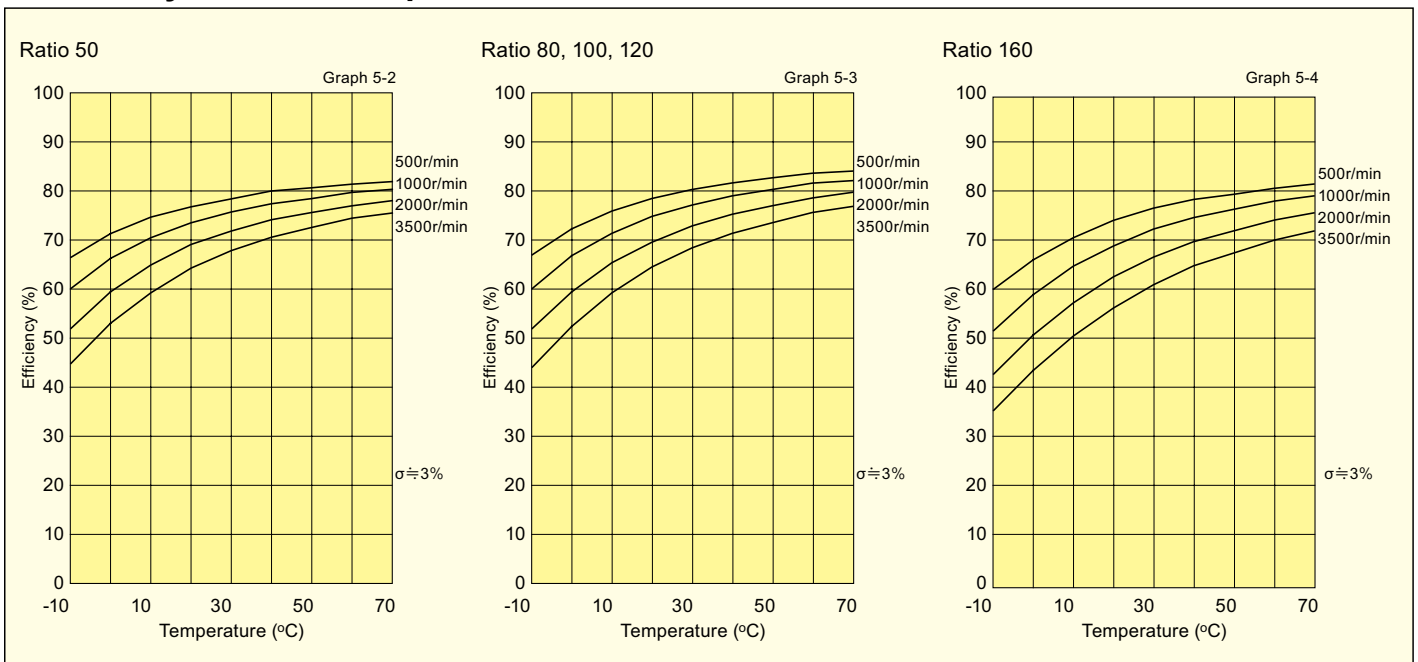

External Dimensions

Figure 6-1

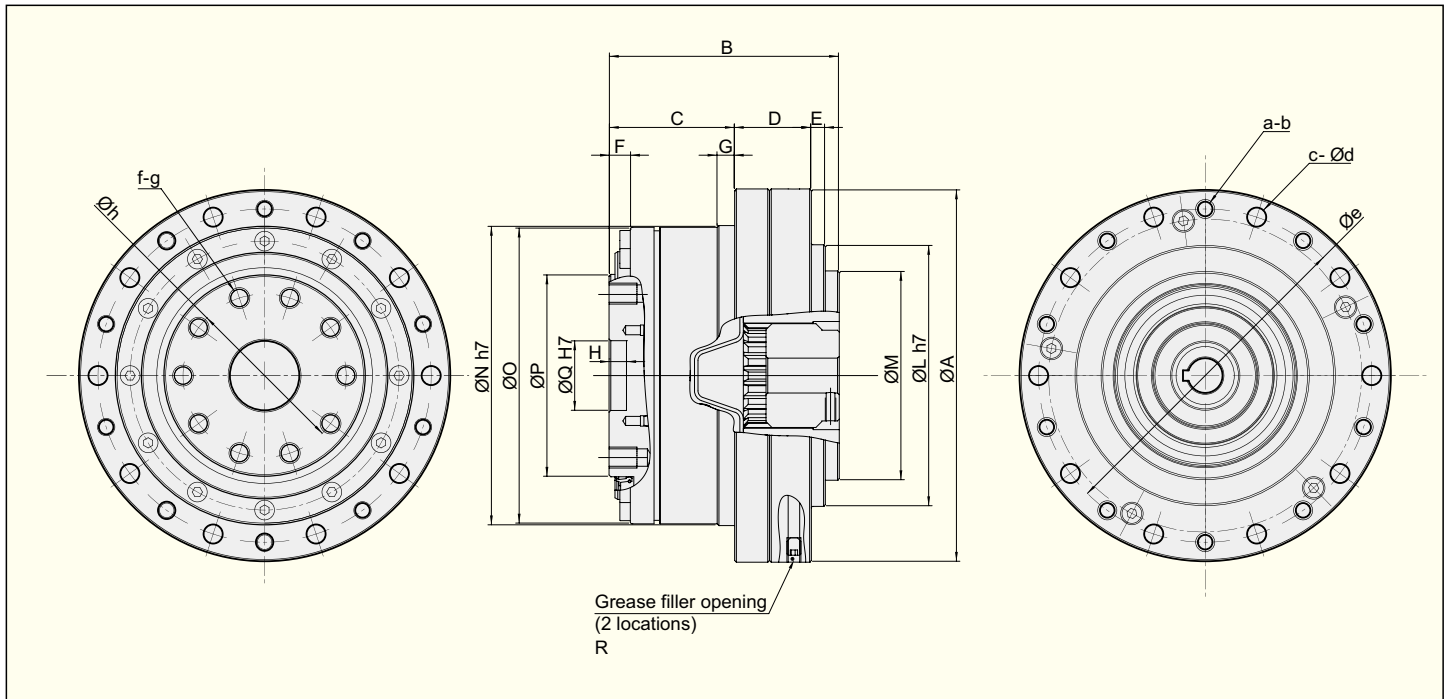

Dimension Table

Table 6-1

Symbol \ Size	25	32	40	45	58	65
φA	107	138	160	180	226	260
B	66	75	85	102	120	129
C	36	45	50.5	58	77	84.5
D	22	24	30	32	37	38.5
E	4	4	4.5	7	6	6
F	6.1	6	7.1	7.6	8.5	9
H	5	5	5	6	10	6
φLh7	75	100	120	135	170	198
φM	60	60	-	108	-	-
φNh7	86	113	127	148	186	212
φO	85	112	126	147	185	210
φP	58	78	90	107	135	155
φQH7	20	26	32	32	46	52
R	M4 P=0.7	M5 P=0.8	M5 P=0.8	M6 P=1	M6 P=1	M6 P=1
a	10	12	10	12	12	8
b	M5	M6	M8	M8	M10	M12
c	10	12	10	12	12	8
φd	5.5	6.6	9	9	11	14
φe	96	125	144	164	206	236
f	10	10	12	12	8	12
g	M6	M8	M8	M10	M16	M14
φh	47	62	72	84	104	120
Mass (kg)	2.2	4.5	6.5	9.7	18.5	26.3

Unit: mm

■ Input Spline External Dimensions

Figure 7-1

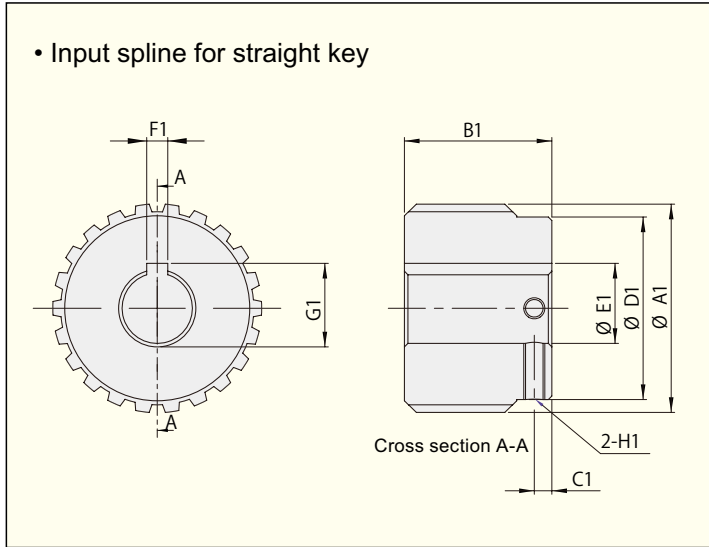
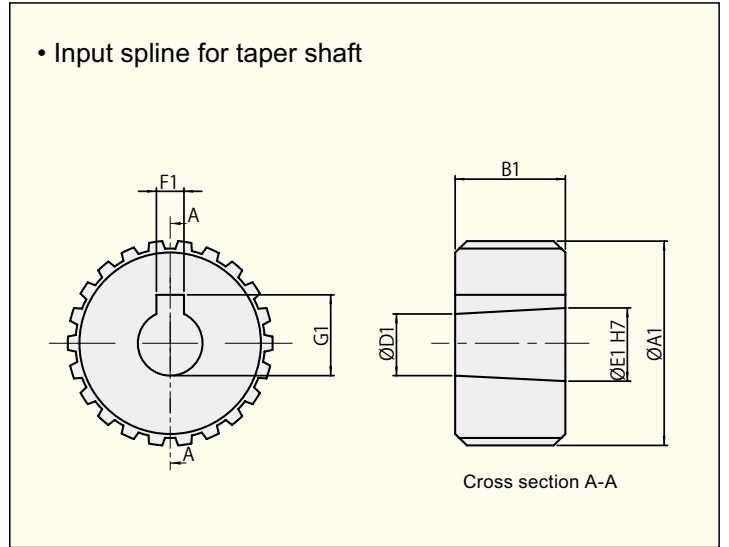

Figure 7-2



■ Dimension Table

Table 7-1

Form symbols of input spline	A01		A02		A03		A04		A05	B01	B02	B03	C01			C02			C03			C04			C05		
Shaft shape	Straight φ14		Straight φ10		Taper φ11		Taper φ14		Taper φ16	Straight φ24	Taper φ16	Straight φ19	Straight φ35			Taper φ16			Straight φ19			Straight φ24			Taper φ32		
Size	25	32	25	32	25	32	25	32	32	40	40	40	45	58	65	45	58	65	45	58	65	45	58	65	45	58	65
φA1	29.75		29.75		29.75		29.75		29.75	44.667	44.667	44.667	54.5			54.5			54.5			54.5			54.5		
B1	21		21		16		19		29	37	29	37	62			29			37			37			50		
C1	2.5		2.5		-		-		-	5.8	-	5.8	12.5			-			5.8			5.8			-		
φD1	26		26		9.4		12.1		13.1	39.4	13.1	40	48			13.1			48			48			26		
φE1	14 ^{+0.034} ₀		10 ^{+0.015} ₀		11 ^{+0.018} ₀		14 ^{+0.018} ₀		16 ^{+0.018} ₀	24 ^{+0.021} ₀	16 ^{+0.018} ₀	19 ^{+0.021} ₀	35 ^{+0.035} _{+0.010}			16 ^{+0.018} ₀			19 ^{+0.021} ₀			24 ^{+0.021} ₀			31 ^{+0.025} ₀		
F1	5 ^{+0.015} ₀		3 ^{+0.013} ₀		4 ^{+0.015} ₀		4 ^{+0.015} ₀		5 ^{+0.015} ₀	8 ^{+0.018} ₀	5 ^{+0.015} ₀	6 ^{+0.015} ₀	10 ^{+0.018} ₀			5 ^{+0.015} ₀			6 ^{+0.015} ₀			8 ^{+0.018} ₀			7 ^{+0.018} ₀		
G1	16.3 ^{+0.1} ₀		11.4 ^{+0.1} ₀		12.5 ^{+0.1} ₀		15.8 ^{+0.1} ₀		17.6 ^{+0.1} ₀	27.3 ^{+0.2} ₀	17.6 ^{+0.1} ₀	21.8 ^{+0.1} ₀	38.3 ^{+0.2} ₀			17.6 ^{+0.1} ₀			21.8 ^{+0.1} ₀			27.3 ^{+0.2} ₀			33.8 ^{+0.1} ₀		
H1	M3		M3		-		-		-	M5	-	M5	M5			-			M5			M5			-		

Unit: mm

■ Input Flange Axial Direction Range Dimensions

Figure 7-3

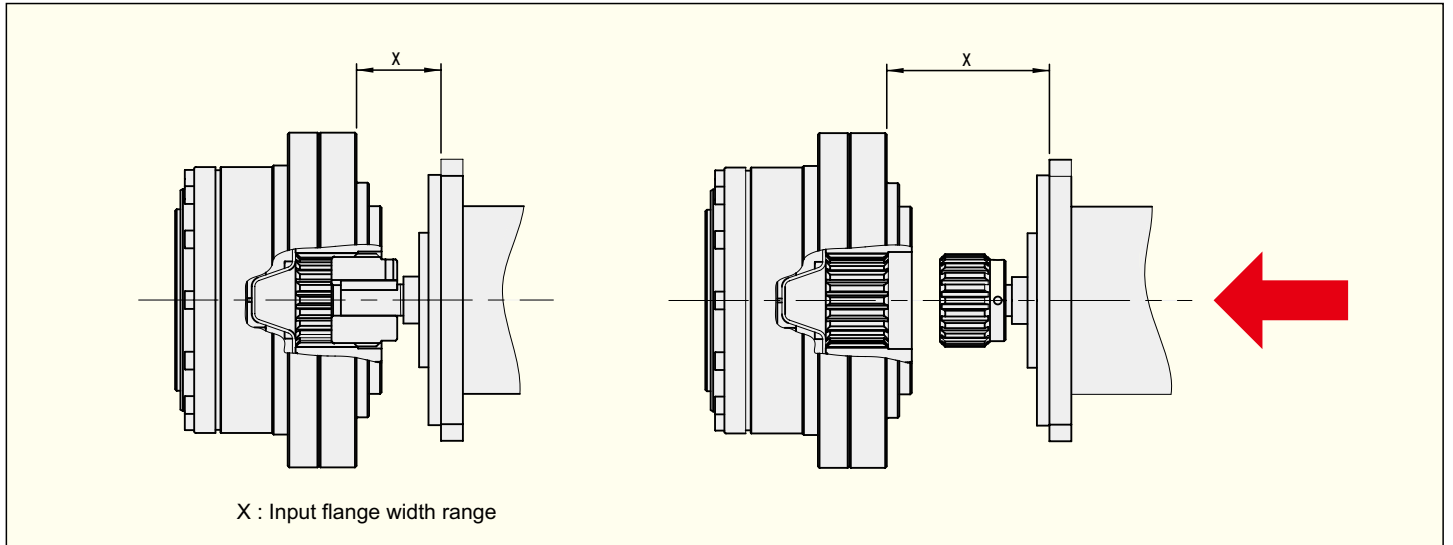

■ Dimension Table

Table 7-2

Form Symbols of Input Spline	A01		A02		A03		A04		A05	B01	B02	B03	C01			C02			C03			C04			C05		
Shaft Shape	Straight φ14		Straight φ10		Taper φ11		Taper φ14		Taper φ16	Straight φ24	Taper φ16	Straight φ19	Straight φ35			Taper φ16			Straight φ19			Straight φ24			Taper φ32		
Size	25	32	25	32	25	32	25	32	32	40	40	40	45	58	65	45	58	65	45	58	65	45	58	65	45	58	65
Xmin	13	11	13	11	13	11	14	11	21	22	14.5	22.5	48.8	31.6	27.8	16	11	-	24	-	-	12	9	-	63.8	43.8	38.8
Xmax	17.1	14	21.1	18	16.1	13	23.5	16	28	33.8	25.8	34.8	56.8	56.2	56.2	22	21.4	-	31	-	-	18.1	29.4	-	63.8	62.4	74

Unit: mm

■ Servo Motor Matching Table

Descriptions in the table

CSG-25-50	1st row: product size
(0.7)	2nd row: reducer inertia: (x 10 ⁻⁴ kgm ²)
(0.2)	3rd row: inertia ratio: reducer inertia/motor inertia

Color-code in the table

Size	Color	Size	Color	Size	Color
25		40		58	
32		45		65	

FANUC

aiS series

Table 8-1

Motor	Ratio				
Series	50	80	100	120	160
aiS 2/5000	CSG-25-50 (0.7) (0.2)	CSG-25-80 (0.7) (0.2)	CSG-25-100 (0.7) (0.2)	CSG-25-120 (0.7) (0.2)	CSG-32-160 (1.4) (0.5)
aiS 2/6000	CSG-25-50 (0.7) (0.2)	CSG-25-80 (0.7) (0.2)	CSG-25-100 (0.7) (0.2)	CSG-25-120 (0.7) (0.2)	CSG-32-160 (1.4) (0.5)
aiS 4/5000	CSG-32-50 (1.4) (0.3)	CSG-32-80 (1.4) (0.3)	CSG-32-100 (1.4) (0.3)	CSG-32-120 (1.4) (0.3)	CSG-32-160 (1.4) (0.3)
aiS 8/4000	CSG-40-50 (3.5) (0.3)	CSG-40-80 (3.5) (0.3)	CSG-40-100 (3.5) (0.3)	CSG-40-120 (3.5) (0.3)	
	CSG-45-50 (8.8) (0.8)	CSG-45-80 (8.8) (0.8)	CSG-45-100 (8.8) (0.8)	CSG-45-120 (8.8) (0.8)	CSG-45-160 (8.8) (0.8)
aiS 8/6000	CSG-40-50 (3.5) (0.3)	CSG-40-80 (3.5) (0.3)	CSG-40-100 (3.5) (0.3)	CSG-40-120 (3.5) (0.3)	CSG-40-160 (3.5) (0.3)
			CSG-45-100 (8.8) (0.8)	CSG-45-120 (8.8) (0.8)	CSG-45-160 (8.8) (0.8)
aiS 12/4000	CSG-40-50 (3.5) (0.2)				
	CSG-45-50 (8.8) (0.4)	CSG-45-80 (8.8) (0.4)	CSG-45-100 (8.8) (0.4)	CSG-45-120 (8.8) (0.4)	CSG-45-160 (8.8) (0.4)
					CSG-58-160 (19.9) (0.9)
aiS 22/4000		CSG-58-80 (19.9) (0.9)	CSG-58-100 (19.9) (0.9)	CSG-58-120 (19.9) (0.9)	CSG-58-160 (19.9) (0.9)
		CSG-65-80 (43.8) (0.8)	CSG-65-100 (43.8) (0.8)	CSG-65-120 (43.8) (0.8)	CSG-65-160 (43.8) (0.8)

FANUC

aiF series

Table 8-2

Motor	Ratio				
Series	50	80	100	120	160
aiF 1/5000					CSG-25-160 (0.7) (0.2)
aiF 2/5000	CSG-25-50 (0.7) (0.1)	CSG-25-80 (0.7) (0.1)	CSG-25-100 (0.7) (0.1)	CSG-25-120 (0.7) (0.1)	
					CSG-32-160 (1.4) (0.3)
aiF 4/4000	CSG-32-50 (1.4) (0.1)	CSG-32-80 (1.4) (0.1)	CSG-32-100 (1.4) (0.1)	CSG-32-120 (1.4) (0.1)	
					CSG-40-160 (3.5) (0.3)
aiF 8/3000	CSG-40-50 (3.5) (0.1)	CSG-40-80 (3.5) (0.1)	CSG-40-100 (3.5) (0.1)	CSG-40-120 (3.5) (0.1)	CSG-40-160 (3.5) (0.1)
				CSG-45-120 (8.8) (0.3)	CSG-45-160 (8.8) (0.3)
aiF 12/3000	CSG-45-50 (8.8) (0.1)	CSG-45-80 (8.8) (0.1)	CSG-45-100 (8.8) (0.1)	CSG-45-120 (8.8) (0.1)	
					CSG-58-160 (19.9) (0.3)
aiF 22/3000		CSG-58-80 (19.9) (0.2)	CSG-58-100 (19.9) (0.2)	CSG-58-120 (19.9) (0.2)	CSG-58-160 (19.9) (0.2)
				CSG-65-120 (43.8) (0.4)	CSG-65-160 (43.8) (0.4)

■ Servo Motor Matching Table

Descriptions in the table

CSG-25-50	1st row: product size
(0.7)	2nd row: reducer inertia: (x 10 ⁻⁴ kgm ²)
(0.2)	3rd row: inertia ratio: reducer inertia/motor inertia

Color-code in the table

Size	Color	Size	Color	Size	Color
25		40		58	
32		45		65	

FANUC

βiS series

Table 9-1

Motor Series	Ratio				
	50	80	100	120	160
βiS 2/4000	CSG-25-50 (0.7) (0.2)	CSG-25-80 (0.7) (0.2)	CSG-25-100 (0.7) (0.2)	CSG-25-120 (0.7) (0.2)	CSG-25-160 (0.7) (0.2)
	CSG-25-50 (0.7) (0.1)	CSG-25-80 (0.7) (0.1)			
βiS 4/4000		CSG-32-80 (1.4) (0.3)	CSG-32-100 (1.4) (0.3)	CSG-32-120 (1.4) (0.3)	CSG-32-160 (1.4) (0.3)
	CSG-40-50 (3.5) (0.3)	CSG-40-80 (3.5) (0.3)	CSG-40-100 (3.5) (0.3)	CSG-40-120 (3.5) (0.3)	CSG-40-160 (3.5) (0.3)
βiS 8/3000					CSG-45-160 (8.8) (0.8)
	CSG-40-50 (3.5) (0.2)	CSG-40-80 (3.5) (0.2)	CSG-40-100 (3.5) (0.2)	CSG-40-120 (3.5) (0.2)	CSG-40-160 (3.5) (0.2)
βiS 12/2000	CSG-45-50 (8.8) (0.4)		CSG-45-100 (8.8) (0.4)	CSG-45-120 (8.8) (0.4)	CSG-45-160 (8.8) (0.4)
	CSG-40-50 (3.5) (0.2)	CSG-40-80 (3.5) (0.2)	CSG-40-100 (3.5) (0.2)	CSG-40-120 (3.5) (0.2)	
βiS 12/3000	CSG-45-50 (8.8) (0.4)	CSG-45-80 (8.8) (0.4)	CSG-45-100 (8.8) (0.4)	CSG-45-120 (8.8) (0.4)	CSG-45-160 (8.8) (0.4)
	CSG-45-50 (8.8) (0.2)	CSG-45-80 (8.8) (0.2)	CSG-45-100 (8.8) (0.2)	CSG-45-120 (8.8) (0.2)	
βiS 22/1500				CSG-58-120 (19.9) (0.4)	CSG-58-160 (19.9) (0.4)
	CSG-45-50 (8.8) (0.2)	CSG-45-80 (8.8) (0.2)	CSG-45-100 (8.8) (0.2)	CSG-45-120 (8.8) (0.2)	
βiS 22/2000				CSG-58-120 (19.9) (0.4)	CSG-58-160 (19.9) (0.4)
	CSG-45-50 (8.8) (0.2)	CSG-45-80 (8.8) (0.2)	CSG-45-100 (8.8) (0.2)	CSG-45-120 (8.8) (0.2)	
					CSG-65-160 (43.8) (0.8)

■ Main Roller Bearing Specifications

Table 10-1

Size	Pitch Circle	Offset	Basic Dynamic Rated Load C		Basic Static Rated Load Co		Allowable Moment Load Mc		Moment Stiffness	
	m	m	×10 ² N	kgf	×10 ² N	kgf	Nm	kgfm	×10 ⁴ Nm/rad	kgfm/arc-min
25	0.064	0.0118	96	980	151	1540	128	13.1	19.8	5.9
32	0.083	0.0133	150	1530	250	2550	257	26.2	44.2	13.1
40	0.096	0.0148	213	2170	365	3720	369	37.7	74.6	22.1
45	0.111	0.0158	230	2350	426	4340	563	57.4	116	34.4
58	0.141	0.0205	518	5290	904	9230	838	85.4	201	59.6
65	0.160	0.0185	556	5670	1030	10500	1525	156	331	108

■ Installation and Transmission Torque

Bolt connection to output flange(CRB) and resulting transmission torque

Table 10-2

Size		25	32	40	45	58	65
Number of Bolts		10	10	12	12	8	12
Size of Bolts		M6	M8	M8	M10	M16	M14
P.C.D	mm	47	62	72	84	104	120
Bolt Tightening Torque	Nm	18.4	45	45	88	382	246
	kgfm	1.88	4.6	4.6	9.0	39.0	25.1
Torque Transmission Torque	Nm	448	1090	1519	2778	6211	7900
	kgfm	46	111	155	283	634	806

Bolt connection to input side flange and resulting transmission torque

Table 10-3

Size		25	32	40	45	58	65
Number of Bolts		10	12	10	12	12	8
Size of Bolts		M5	M6	M8	M8	M10	M12
P.C.D	mm	96	125	144	164	206	236
Bolt Tightening Torque	Nm	9	15.3	37.2	37.2	73.5	128
	kgfm	0.92	1.56	3.8	3.8	7.5	13.1
Torque Transmission Torque	Nm	541	1194	2095	2863	5678	6312
	kgfm	55	122	214	292	579	644

Mechanical Accuracy

Figure 11-1

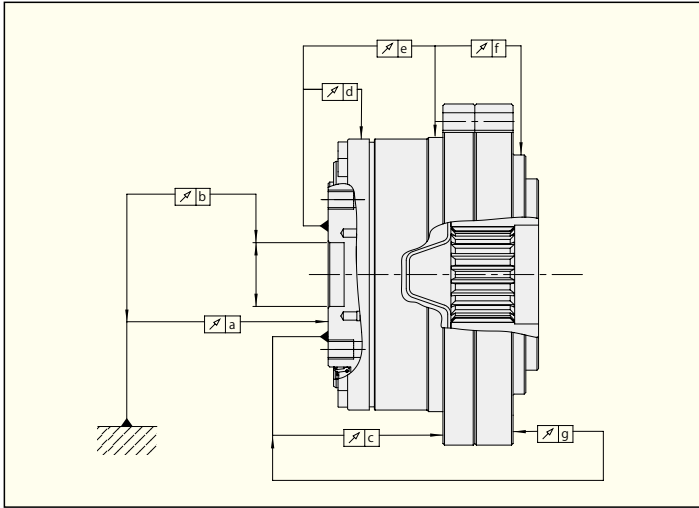

Table 11-1

Symbol	Size	25	32	40	45	58	65
a		0.015	0.015	0.015	0.018	0.018	0.018
b		0.013	0.013	0.015	0.015	0.017	0.017
c		0.045	0.056	0.060	0.068	0.076	0.085
d		0.010	0.010	0.015	0.015	0.015	0.015
e		0.049	0.049	0.060	0.065	0.070	0.075
f		0.157	0.172	0.185	0.200	0.212	0.218
g		0.051	0.061	0.058	0.063	0.075	0.096

Unit: mm

Installation Accuracy

When designing installation, be sure to retain the recommended input flange tolerance indicated in Figure 11-2 and Table 11-2 in order to fully realize the excellent performance of the product.

Figure 11-2

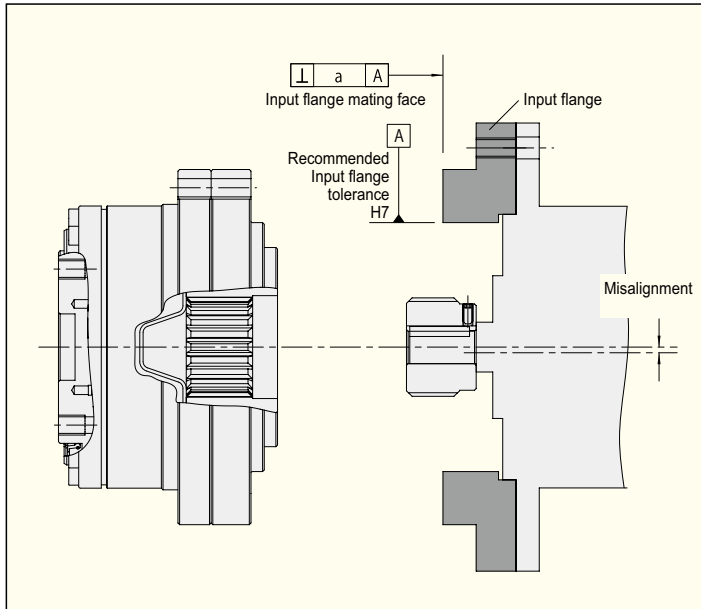

Table 11-2

Symbol	Size	25	32	40	45	58	65
a		0.024	0.026	0.026	0.027	0.031	0.034
Misalignment		0.014	0.014	0.020	0.019	0.019	0.019

Unit: mm

Example of Motor Installation

- Motor straight shaft

Figure 11-3

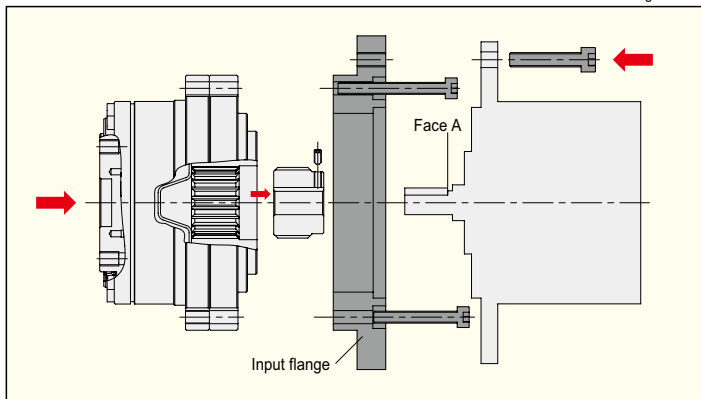

It is recommended to follow the assembly procedure below in order to retain the installation precision:

- (1) Insert the spline into the motor shaft and tighten it.
- (2) Install the input flange to the unit and tighten by bolts.
- (3) Insert a motor into the unit along the input spline and tighten it by bolts.

- Motor taper shaft

Figure 11-4

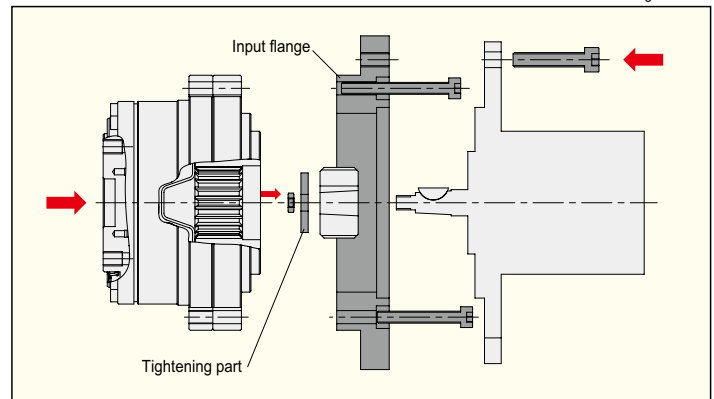

* Because input flange and tightening parts are not provided with a motor, they shall be prepared by the customer.

Lubrication

The lubricant of gear part and cross roller bearing is a Harmonic Grease®4B No.2.

There is no need to inject or apply grease upon installation because the lubricant has been already applied on the unit side of spline.

Figure 12-1

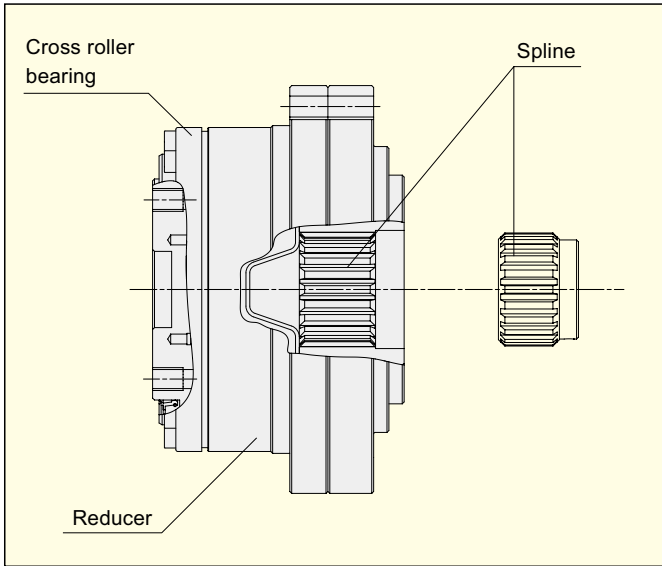

Table 12-1

Gear Part	Harmonic Grease®4B No.2
Crossed Roller Bearing Part	Harmonic Grease®4B No.2
Spline Area	MOLUB-ALLOY 777

Continuous Operating Time

Temperature rises inside CSG-2UK due to the impacts of oil seal and sustaining bearing that are used in the input shaft (on the high-speed rotation side). In the case of continuous operation, operate CSG-2UK within the operating time indicated in Table 12-3.

The continuous operating time in Table 12-3 is determined based on the time when the temperature inside the unit rises to 80 °C and the temperature at oil seal area rises to 100°C under the setting conditions in Table 12-2.

In the case of continuous operation, take the above described upper limit temperatures into consideration with reference to Table 12-3, so as not to exceed them.

Consult us when the above described temperatures are exceeded because taking the following measures should be considered:

- Replacement of lubrication agent at early timing
- Measures for unit radiation
- Measures for leakage of lubrication agent due to the rise of unit inner pressure
- Measures for the oil seal area deterioration due to heat

Note: In the case of model numbers 25 and 32, the unit inner temperature does not exceed 80 °C under the setting conditions.

Caution

- Be careful to avoid radial load on the input side.
- The anti-corrosion treatment is not applied on the surface of the product. Apply rust-preventive agent on the surface as needed. Contact us if you request to apply the rust-preventive treatment by us.

Table 12-2

Installation condition

Operating Temperature (atmosphere)	25 °C
Input Speed	2000 r/min
Radiation Plate	None (single unit radiation only)

Table 12-3

Installation condition

No Load Operating Time Continuous Operating Time	
25	— (Note)
32	— (Note)
40	35
45	50
58	50
65	50

* Please contact the sales office of Harmonic Drive Systems Inc. for more information.

	Head Office:	Ichigo Omori Building 7F, 6-25-3 Minami-Oi, Shinagawa-ku, Tokyo 140-0013 JAPAN Phone: +81-3-5471-7800 / FAX: +81-3-5471-7811	Kansai Office:	Shin-Osaka Ueno Toyo Building 3F, 7-4-17 Nishi-nakajima, Yodogawa-ku, Osaka-shi, Osaka 532-0011 JAPAN Phone: +81-6-6885-5720 / FAX: +81-6-6885-5725
	Overseas Division:	1856-1 Hotakamaki, Azumino-shi, Nagano 399-8305 JAPAN Phone: +81-263-83-6935 / FAX: +81-263-83-6901	Kyushu Office:	NOF Hakata-ekimae Building 7F, 1-15-20 Hakata-ekimae, Hakata-ku, Fukuoka-shi, Fukuoka 812-0011 JAPAN Phone: +81-92-451-7208 / FAX: +81-92-481-2493
	Tokyo Office:	Ichigo Omori Building 7F, 6-25-3 Minami-Oi, Shinagawa-ku, Tokyo 140-0013 JAPAN Phone: +81-3-5471-7830 / FAX: +81-3-5471-7836	Hotaka Plant:	1856-1 Hotakamaki, Azumino-shi, Nagano 399-8305 JAPAN Phone: +81-263-83-6800 / FAX: +81-263-83-6901
	Kitakanto Office:	Ichigo Omori Building 2F, 6-25-3 Minami-Oi, Shinagawa-ku, Tokyo 140-0013 JAPAN Phone: +81-3-6410-8485 / FAX: +81-3-6410-8486	Harmonic Drive AG:	Hoenbergstrasse 14 D-65555 Limburg a.d. Lahn GERMANY Phone: +49-6431-5008-0 / FAX: +49-6431-5008-119
	Koshin Office:	1856-1 Hotakamaki, Azumino-shi, Nagano 399-8305 JAPAN Phone: +81-263-83-6910 / FAX: +81-263-83-6911	Harmonic Drive L.L.C.:	247 Lynnfield Street, Peabody, MA 01960 U.S.A. Phone: +1-978-532-1800 / FAX: +1-978-532-9406
	Chubu Office:	Nagoya Inter Building 6F, 2-173-4 Hongo, Meito-ku, Nagoya-shi, Aichi 465-0024 JAPAN Phone: +81-52-773-7451 / FAX: +81-52-773-7462	Harmonic Drive Systems (Shanghai) Co., Ltd.:	Rm206, 1# No.641, Tianshan Rd, Changning District, Shanghai, 200336, CHINA Phone: +86-21-6237-5656 / FAX: +86-21-3250-7268

"HarmonicDrive" is a trademark of Harmonic Drive Systems Inc. The academic or generic term of our products "HarmonicDrive" is "strain wave gearing." The trademark is registered in Japan, Korea and Taiwan.



Registered Trademark in Japan
No.1601-2R-CSG2UK-news19